



LIGHTING

S P U N
-
C O L L E C T I O N

LADIES & GENTLEMEN STUDIO

LADIES & GENTLEMEN STUDIO

ABOUT THE COLLECTION

L&G believes that thoughtful pairings of form, function, and materiality can enrich spatial experiences in unexpected ways. In this spirit, their furniture and lighting collection features simple statement pieces intended to quietly add sophistication, utility, and playfulness to an interior.

L&G's open and collaborative design approach provides clients with three levels of service depending on the needs of their project:

Standard -

Select items from L&G's collection, thoughtfully composed for optimal pairings of form, fit, and finish.

Tailored -

All standard products can be adapted in a variety of ways. L&G works with clients to create finishes, sizes, and configurations of standard products to complement the character of a space.

Commissioned -

L&G collaborates directly with clients to create original site-specific work. From large scale to small, projects are enriched when L&G's design perspective and creative solutions are combined with a deep understanding of the project's parameters.

ABOUT L&G STUDIO

L&G Studio's aesthetic and design philosophy is a balanced blend of warm minimalism, playful austerity, and simple sophistication. Founded by Dylan Davis & Jean Lee in 2010, L&G Studio's playful explorations in materiality blend their resourceful curiosity with the desire to find unexpected pairings of material and function. Their focus is on creating a diverse set of products from small objects, home decor goods, jewelry, to furniture, lighting, and beyond. Their open, multidisciplinary approach to design yields an unexpected, ever-evolving set of ideas and experiments collected from their everyday discoveries, explorations, and surroundings.



SPUN COLLECTION

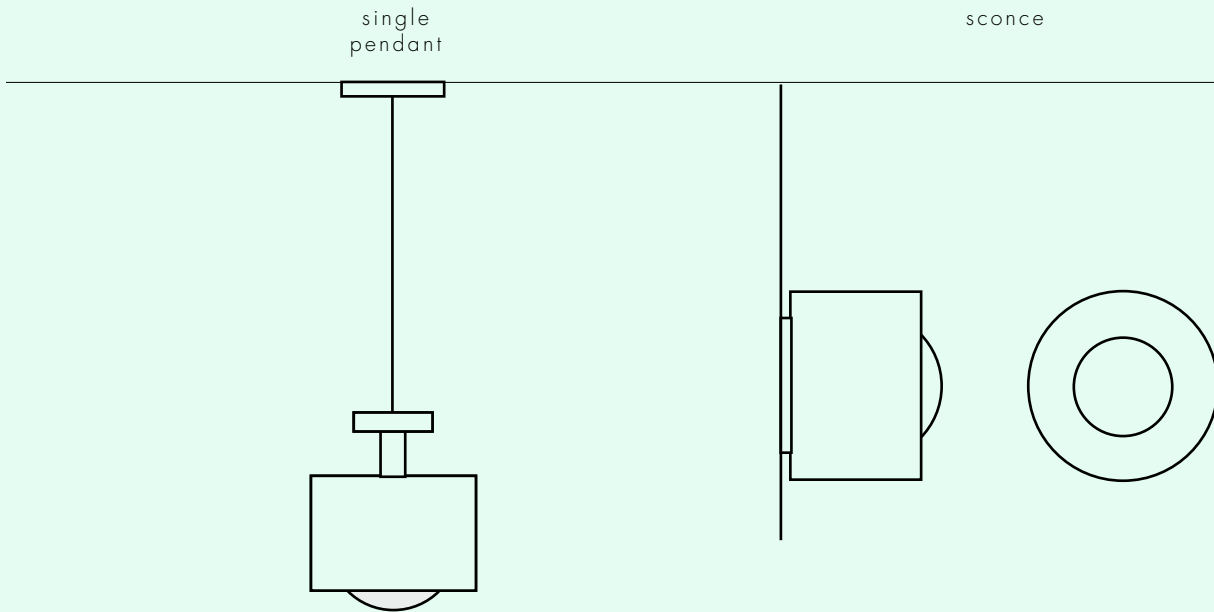

Spun, Ladies & Gentlemen's original lighting series produced by Seattle-based Standard Socket considers lighting as the most essential accessory to a space. As if designing jewelry, L&G considered how each lighting component could complement the other to create tidy elegant compositions. Spun features a polished brass shade, which encases an exposed globe light bulb. An adjustable interior reflector (in black or white) causes the bulb to sit in the housing like a precious stone.

The Spun series is made to order by L&G studio.

3 light cluster

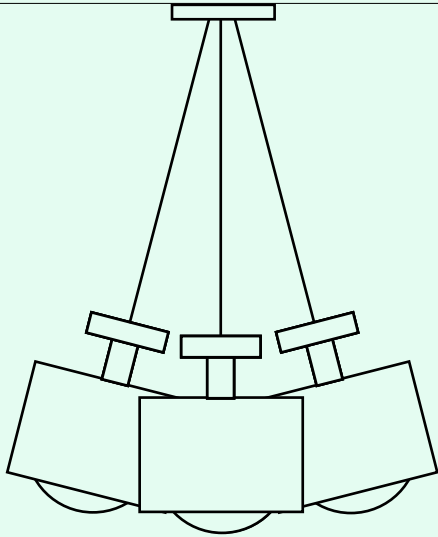

5 light cluster

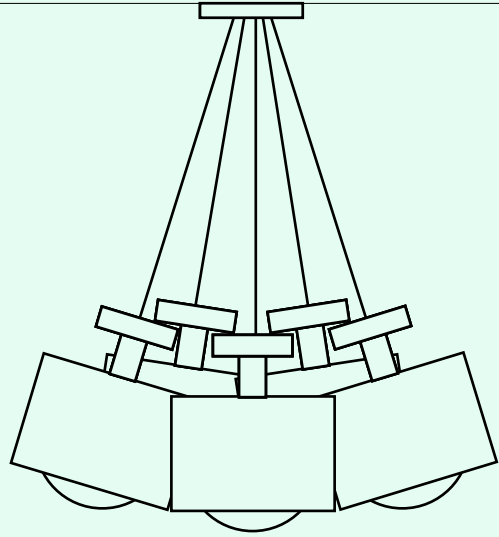

SPUN PENDANT

LADIESANDGENTLEMENSTUDIO.COM



SPUN PENDANT

LADIESANDGENTLEMENSTUDIO.COM

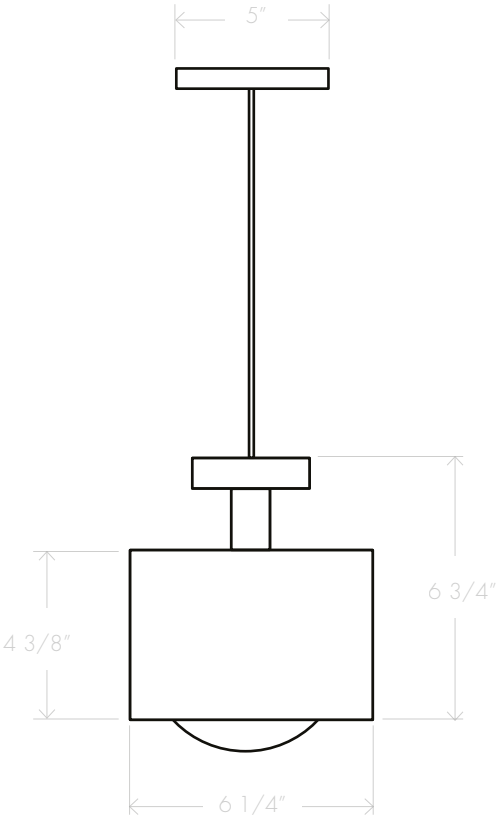

- blackened
- brass
- copper
- aluminum

appearance

materials copper, brass, maple, fabric cord, powder coated steel

suspension 8' brown fabric cord, adjustable

canopy 5" round black or white powdercoated

finishes anodized aluminum, brass, copper, blackened metal

style options black or white diffuser panel

customize finish, cord, config. (clusters)

technical

socket/lamp E26 ; bulb: G25/G125 globe (incandescent recommended)

watt/volt max 75w; line voltage to 300v

compatibility most international

certification ul, cUL

weight 4 lb

lead time 8-10 weeks

SPUN SCONCE

LADIESANDGENTLEMENSTUDIO.COM



SPUN SCONCE

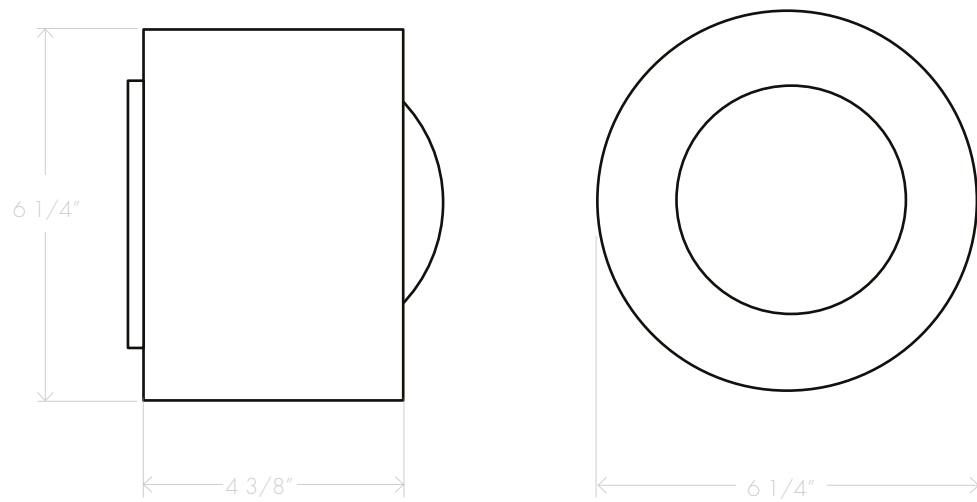

LADIESANDGENTLEMENSTUDIO.COM

- blackened
- brass
- copper
- aluminum

appearance

materials copper, brass, maple, fabric cord, powder coated steel

finishes anodized aluminum, brass, copper, blackened metal

style options black or white diffuser panel

customize finish, cord, config. (clusters)

technical

socket/lamp E26 ; bulb: G25/G125 globe (incandescent recommended)

watt/volt max 75w; line voltage to 300v

compatibility most international

certification ul, cUL

weight 4 lb

lead time 8-10 weeks

SPUN CLUSTER

LADIESANDGENTLEMENSTUDIO.COM



SPUN CLUSTER

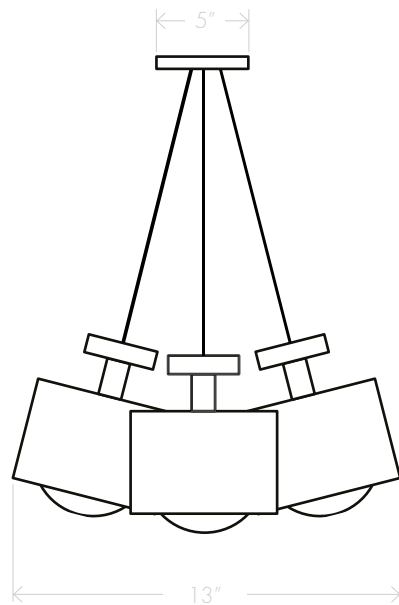

3-LIGHT CLUSTER

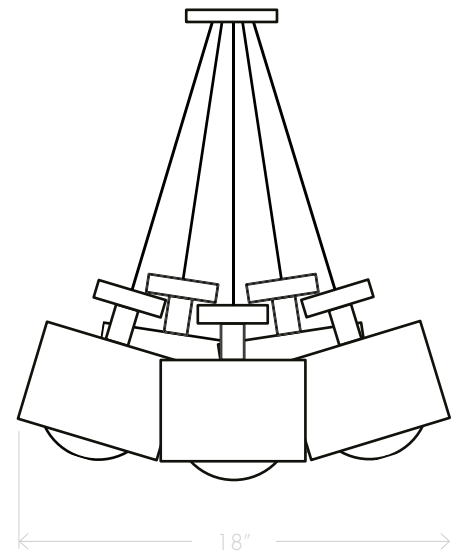

5-LIGHT CLUSTER

-  blackened
-  brass
-  copper
-  aluminum

appearance

- materials** copper, brass, maple, fabric cord, powder coated aluminum
- suspension** 8' brown fabric cord, adjustable
- canopy** 5" round black or white powdercoated
- finishes** anodized aluminum, brass, copper, blackened metal
- style options** 3 pc cluster or 5 pc cluster; black or white diffuser panel
- customize** finish, cord, config. (clusters)

technical

- socket/lamp** E26 ; bulb: G25/G125 globe (incandescent recommended)
- watt/volt** max 75w; line voltage to 300v
- compatibility** most international
- certification** ul, cUL
- weight** 12 lb; 20 lb.
- lead time** 8-10 weeks

- CONTRIBUTORS -

Photography:
Charlie Schuck
Kaarem

Print Design:
Sophie Borch-Jacobsen

- CONTACT INFO -

201 Richards Street
Suite 215
Brooklyn NY 11231
USA

425.610.7408
info@ladiesandgentlemenstudio.com

- WEBSITE -

LADIESANDGENTLEMENSTUDIO.COM